

# COWLEY COUNTY FAIR ASSOCIATION

## FIGURE 8 RACES

### RULES AND REGULATIONS

**FRIDAY, JULY 30<sup>TH</sup>, 2010**

[www.cowleycountyfair.com](http://www.cowleycountyfair.com)

### **ENTRY RULES**

1. Entry fee will be \$ 20.00 per car. Early entries must be in by 5 pm. Thursday July 22<sup>nd</sup> 2010 or will be considered late. This will admit one driver and two mechanics. Late entries will be \$ 30.00 per car and will start at the back of qualification heats.
2. Entries will be limited to 42 cars. Entry must accompany all entries.
3. All cars must be in the pit area before 6:00 pm. Entrance is at the south end off of 14<sup>th</sup> St.
4. All cars will be inspected by 6:30 pm. and must pass.
5. Cars must be removed from the grounds before 10:00 am. Saturday, July 31<sup>st</sup>, 2010 or will become property of Cowley County Fair Assn.
6. Entry fee refunds will be made only on cars that do not pass inspection. (NO SHOW-NO REFUND).
7. Extra pit passes will be sold at the pit gate for \$20.00 each. Must be 18 yrs of age.
8. MISCONDUCT WILL RESULT IN BEING REMOVED FROM THE GROUNDS.
9. No entries will be taken over the telephone.
10. No entries will be taken after 5:00 pm. July 27<sup>th</sup> 2010.
11. The pit area will be closed to all children and family members before and during this event and 30 minutes after the race is over.
12. Drivers and car must enter before pit crew will be allowed into the pit area.

### **CAR PREPERATION**

1. All glass and chrome must be removed before entering the grounds. All loose items must be removed from the car including items in the trunk and door panels.
2. Doors and trunk lid must be welded shut or chained with a minimum 5/16" chain.
3. Hood can be chained with a minimum 5/16" chain or no more than 4, 3/4" all thread.
4. Gas tank must be removed. Gas tank is a maximum of 6 gallons and fastened securely in the rear seat area. For drivers safety, a metal tank is recommended and a metal box covering gas tank.
5. Batteries must be moved to the front seat compartment and securely fastened.
6. Air cleaners must be left in place.
7. Drivers' door reinforcement must be added. **NO GRADER BLADES**
8. Drivers' compartment MUST have a 4 point roll bar. A minimum of 2" OD. Pipe may be used.
9. Holes must be cut in the hood large enough for a fire extinguisher to be used.
10. Radiator must be left in place. A support from the top of the radiator support to the roll cage only will be allowed. Electric fans can be used but must be in the engine compartment.
11. All wheel and tire balancing weights must be removed. DOT approved tires only.
12. For safety reasons, clean engine of oil and grease.
13. For safety reasons, leave fire wall intact and heater cores covered.
14. All cars will be given a number upon passing inspection. The number will be on the top of the car.
15. Wheels will not be modified. No iron welded on.
16. No numbers will be on the cars except the number assigned at inspection.
17. Numbers will be on a three sided sign 16" X 16" on the top of the car.
18. A piece of pipe or square tubing, no more than 4" and no longer than the frame horns can be used for a bumper, front and rear. A push bar can be welded to the bumpers but no taller than 12" and no longer than the frame horns.
19. A piece of pipe or sucker rod (maximum 1" diameter) is required from the firewall to the top of the car roof or roll bar to keep the hood from coming into car.
20. Seat belt and shoulder harness must be permanently mounted.

## DRIVERS RULES

1. All drivers must be at least 18 years of age. All persons entering the pit area must sign a waiver releasing the COWLEY COUNTY FAIR ASSN. from liability.
2. Helmets with face shields or goggles must be worn. If helmet or eye protection comes off or is removed during a race, driver will be disqualified from that race.
3. Seat belt and shoulder harness must be worn at all times.
4. Hail screen may be placed in the windshield area in front of the driver only.
5. Drivers will be disqualified if any door or hood comes open during that race.
6. Drivers must be present at the drivers meeting held at 7:00 pm. Roll call will be called.
7. When call goes out to be in place, drivers have two minutes to be in place or will be disqualified for that race.
8. Any car catching fire will be allowed one restart per race.
9. Any car that rolls over will be allowed one restart per race.
10. All cars must stop immediately when red flag come out.
11. Drivers must stay in car until race is over, except for a fire.
12. Drivers must keep arms and hands inside of car during race.
13. Flagging will be in accordance with stock car racing, and will be explained at drivers meeting.
14. All cars are subject to reinspection at any time.
15. All rulings by race manager are final.
16. For safety reasons, we recommend that you wear a neck roll.
17. Jeans and long sleeve shirts are required.

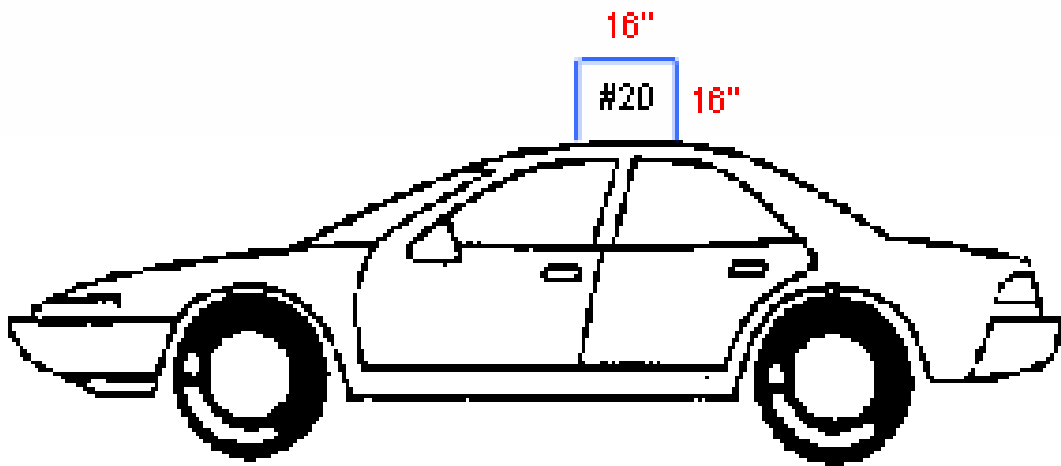
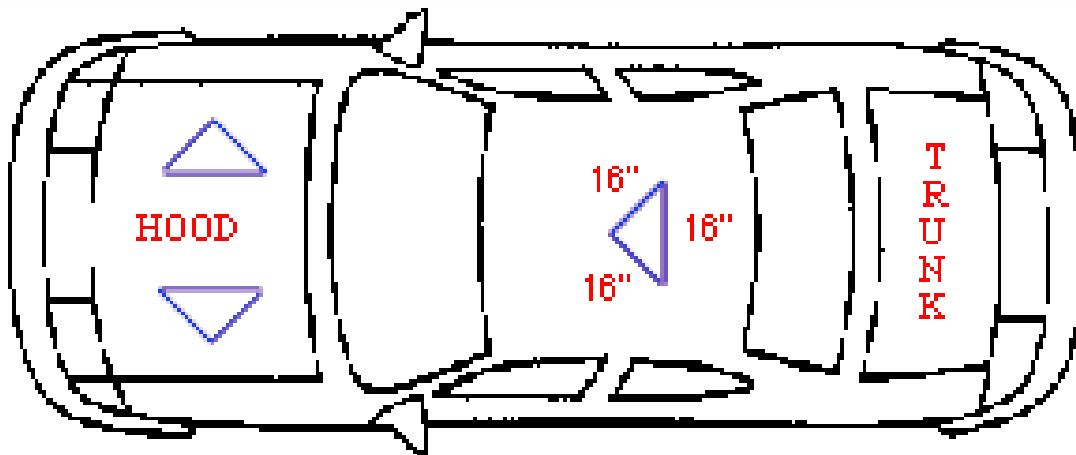

2010 ENTRY FORM COWLEY COUNTY FAIR  
FIGURE 8 RACES  
FRIDAY, JULY 30<sup>TH</sup> 2010 AT 7:30 P.M.

NAME \_\_\_\_\_ MECHANIC #1 \_\_\_\_\_  
ADDRESS \_\_\_\_\_ MECHANIC #2 \_\_\_\_\_  
CITY & STATE \_\_\_\_\_ ZIP CODE \_\_\_\_\_  
TELEPHONE \_\_\_\_\_

Mechanics listed are the only ones admitted with entry  
There will be no substitutions

**NO ALCOHOLIC BEVERAGES WILL BE ALLOWED IN THE PIT AREA**

**NO ONE UNDER 18 YEARS OF AGE WILL ALLOWED IN THE PIT AREA**

**NO VIDEO PROTESTS WILL BE ALLOWED**

**Entries must be in by 5:00 p.m.**

**July 22<sup>nd</sup>, 2010. \$ 20.00**

**July 23<sup>rd</sup> --27<sup>th</sup>, 2010 \$ 30.00**

**No entries will taken after July 27<sup>th</sup>, 2010**

**PRIZE MONEY AND TROPHIES**

- \* A FEATURE WINNER-----\$ 1250.00
- \* A FEATURE SECOND-----\$ 500.00
- \* A FEATURE THIRD-----\$ 300.00
- \* A FEATURE FOURTH-----\$ 150.00
- \* A FEATURE FIFTH-----\$ 100.00
- \* B FEATURE TOP 2-----\$ 20.00 ea.
- \* C FEATURE TOP 2-----\$ 20.00 ea.
- \* D FEATURE TOP 2-----\$ 20.00 ea.
- \* E FEATURE TOP 2-----\$ 20.00 ea.
- \* F FEATURE TOP 2-----\$ 20.00 ea.
- \* ALL QUALIFICATION  
HEAT WINNERS-----\$ 40.00

**MAIL ENTRIES ONLY**

**SEND ENTRIES TO:**

Doug Platter  
13519 136TH RD.  
Winfield, Ks  
67156

Make checks payable to:  
Cowley County Fair Assn

THE TOP 2 FROM THE B, C, D, E AND THE F  
FEATURE WILL MOVE UP TO THE NEXT RACE